

CAPABILITY STATEMENT

DHC-6 TWIN OTTER ^{✈ 3}



CERTIFICATIONS

FAA Part 91 & 135 Air Carrier | CARB Carrier | USSOCOM Commercial Paratroop Air Carrier |
HAZMAT Carrier | FAA Part 145 Repair Station | FAA Part 5 Safety Management System |
Canada TAO | Royal Air Force Paratroop Carrier

☎ +1 815-981-8284

✉ info@winaviation.com

🌐 winaviation.com



SINCE 1996, THE PREMIER AERIAL PLATFORM FOR CONUS AIRBORNE OPERATIONS

Win Aviation is a USSOCOM J-31 inspected and approved, CARB certified and FAA Part 91 and 135 air carrier based at DeKalb Taylor Municipal Airport (DeKalb, IL) and Coolidge Municipal Airport (Coolidge, AZ).

We have a long, established history in the parachute industry, supplying paradrop airlift solutions to military, government and civilian clients in the USA, Canada, Mexico and the United Kingdom since 1996.

As the premier aircraft and aircrew supplier for military parachuting in Southern California and Arizona, we have flown over 70,000 flights executing 1 million jumps in the past six years. We provide a robust service package for the Joint Special Operations Command community for safe, dependable and quality parachute training.

Win Aviation also operates in Canada with its own TOA under the NAFTA agreement and has been approved by the Canadian Department of National Defence for paradrop operations.

Win Aviation aircraft and pilots are further assured by Royal Air Force HQ1Gp, under Military Aviation Authority Regulatory Article 1240, to provide paradrop training support.

MISSION PROFILES

- Static Line and Military Free Fall operations
- HALO/HAHO jumps
- Military tandem tethered bundle drops
- Double-bag Static Line jumps
- Pallet, cargo and CDS bundle drops
- Day and night operations
- Water and ocean drops
- Ultra-cold weather missions
- Infiltration and extraction missions
- Rescue and resupply missions
- Spotter training
- Air-to-air photography



LOCATIONS

We have two FAA Part 145 repair stations and base of operations; the main repair center is located at our Win Aviation Headquarters at DeKalb Taylor Municipal Airport (DeKalb, IL), and our satellite repair station is located at Coolidge Municipal Airport (Coolidge, AZ).

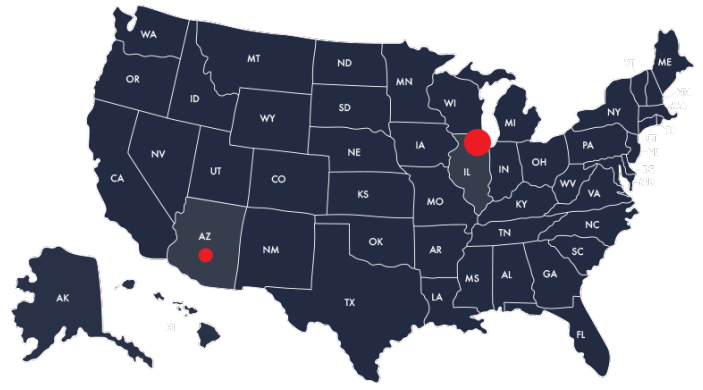

With over 32 aircraft, 20 pilots, 15 A&P certified mechanics, and a dedicated logistics team, Win Aviation is able to deliver unparalleled service and superior airborne capabilities at multiple geographically dispersed locations, simultaneously.

PILOTS

Win Aviation's aircrews consists of seasoned FAA certified commercial and airline transport pilots who are type-rated and IFR-rated in their respective aircraft. Our pilots receive Crew Resource Management and aeronautical decision making in addition to annual in-house and online training to improve their skills and promote safety.

Win Aviation pilots are highly experienced and exclusively fly for military paratroop training missions.

MAINTENANCE

Win Aviation's aircraft are tracked through our proprietary Aviator system and maintained according to the most rigorous industry standards. Aviator records flight times and blade hours, the flight data is then integrated into the maintenance tracking module which provides technicians and crews real time information regarding the maintenance status of each aircraft via QR Code displayed in the flight deck.

Crews are able to notify Win's maintenance team through Aviator regarding any maintenance issues that may arise. Technicians will either be dispatched to the aircraft to make the necessary repairs, alternatively our logistics team will work with the client to dispatch a replacement aircraft.

Our repair stations include all necessary aviation ground equipment, parts, tooling, labor, and expertise to conduct scheduled and unscheduled maintenance on our own fleet as well as private and commercial clients' aircraft.



FLEET ✈️ 3

Win Aviation owns and operates three DHC-6 Twin Otters of which one of the aircraft is FAA Part 135 certified and reflect on our Ops Spec (D085 – Aircraft Listing).

PERFORMANCE & DIMENSIONS

The DHC-6 Twin Otter was developed by De Havilland Canada in the early 1960s as a passenger and cargo transport aircraft. Viking Air later purchased the type certificate and restarted production in 2008. The aircraft is a high wing, un-pressurized twin engine turbine powered aircraft with fixed tricycle landing gear. With its Short Take Off and Landing (STOL) characteristics, the DHC-6 Twin Otter is the best-selling commuter aircraft to date and can operate in the harshest environments. From sub-zero Artic temperatures to the hottest desert climates, the DHC-6 Twin Otter is ideal for missions in remote unimproved locations, including ski and water-based operations.

Our DHC-6 Twin Otters have all been upgraded and are powered by two 715 hp Pratt & Whitney PT6A-27 engines that can carry up to 13 troopers.

Cruise speed	160 kts
Stall speed	56 kts
Range	771 NM/4hrs
Fuel Burn	600 lbs/hour for jump operations
Service ceiling	25,000 ft
Empty weight	5,850 lbs
Max take-off weight	11,500 lbs
Useful load	5,650 lbs
Cabin height	4.9 ft
Cabin length	18.4 ft
Cabin width	5.7 ft
Cabin volume	384 cu ft
Capacity	13 troopers

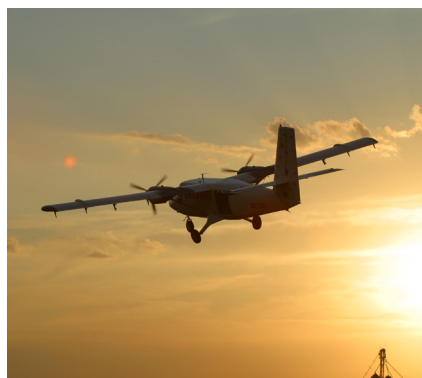
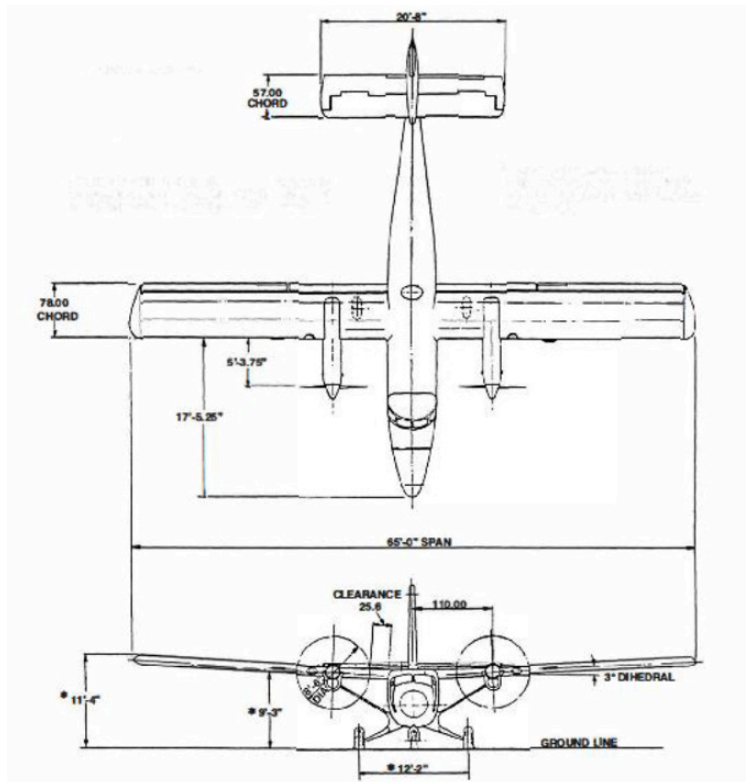

PARADROP EQUIPMENT & CONFIGURATIONS

The DHC-6 Twin Otter cabin is equipped with military grade nylon side benches for troopers and can be configured to include an oxygen manifold and regulator for operations at high altitudes. The large, modified inflight jump door is mechanically controlled by the Jump Master or Instructor.

COMMUNICATIONS

Win Aviation's DHC-6 Twin Otter aircraft is equipped with Avidyne™ IFD440 and Garmin SL40 VHF transceivers. Additional avionics include Stratus™ ES Transponder, Garmin™ GMA340 Audio panel and intercom system, Automatic Dependent Surveillance-Broadcast (ADS-B) and KCS55 Compass System.

To accommodate accurate and safe jump operations, the aircraft is fitted with jump lights (Red/Green).



WHY CHOOSE WIN AVIATION



CONTACT INFORMATION

For more information visit our website or contact us with your inquiry detailing mission/operation requirements and scheduling dates.

Headquarters: 3210 Pleasant Street, DeKalb, IL 60115

Arizona facility: 3644 S Hangar Drive, Coolidge, AZ 85128

Contact details:  +1 815-981-8284

 info@winaviation.com

 winaviation.com

